

OBSTACLE DETECTION AND COLLISION AVOIDANCE USING ULTRASONIC DISTANCE SENSORS FOR AN AUTONOMOUS QUADROPTER

Nils Gageik, Thilo Müller, Sergio Montenegro

University of Würzburg, Aerospace Information Technology (Germany)
Würzburg September 2012

gageik@informatik.uni-wuerzburg.de, montenegro@informatik.uni-wuerzburg.de

Abstract

A simple approach for obstacle detection and collision avoidance of an autonomous flying quadcopter using low-cost ultrasonic sensors and simple data fusion is presented here. The approach has been implemented and tested in a self-developed quadcopter (Figure 1) and its evaluation shows the general realizability as well as the drawbacks of this approach. The presented approach is intended to be used as part of the AQopterI8 project at the department of Aerospace Information Technology (University of Würzburg), which aims to develop an autonomous flying quadcopter for indoor application.



Figure 1: AQopterI8

Keywords: ultrasonic distance sensors, collision avoidance, obstacle detection, quadrotor, quadcopter, UAV

1 INTRODUCTION

Nowadays quadcopters and other civil UAVs (Unmanned Aerial Vehicle) are widespread in the hobby rooms and labs of model-makers, developers and researchers, but not that common in public areas. This may change in the next years as many researchers are working on the improvement and developing applications of such systems. The possible field of applications for an autonomous drone may reach from emergency tool for firefighters and disaster controllers over observation and exploration for both known and unknown areas to many further domains, where ever a small flying machine can help humans in their daily work [2][10][11][12].

Although navigation of an autonomous UAV in an outdoor environment is possible using GPS data for positioning, in indoor this systems are not operational [1]. Other approaches for indoor application use camera systems for obstacle detection, collision avoidance and positioning. These systems lack of different drawbacks like dependency on external camera systems and heavy computation requirements. Further leading approaches use 3D-camera systems like the Kinect camera from Microsoft or laser scanners [9]. However, any optical sensor is sensitive to light and a diaphanous environment. Therefore smoke, steam and every gas which absorbs light will cause optical sensor systems to fail. In contrast, ultrasonic sensors are not effected in such a harsh way, what will be shown in this paper [3].

Approaches using ultrasonic sensors exist, but are not sufficient to support fully autonomous flight as intended [5] [8]. Therefore, a new concept has been designed and implemented, which is presented, evaluated and discussed in this paper.

1.1 CONCEPT OF OBSTACLE DETECTION AND COLLISION AVOIDANCE

The approach is divided into two main modules: One for Obstacle Detection and one for Collision Avoidance. The modules are implemented independently of each other. Hence the concept is still valid and applicable in case of changing or adding sensors of a different kind.

Figure 2 shows the overall concept of the subsystem part, which is presented by this paper. The ultrasonic raw data is filtered and fused altogether and with IMU (inertial measurement unit) data, before it is proceed to the obstacle detection module. The collision avoidance module uses the results of obstacle detection and enables a controlled flight. Remote data from a computer or an RC (Radio Control) controller for activating and deactivating the system as well as sending steering commands are feed through.

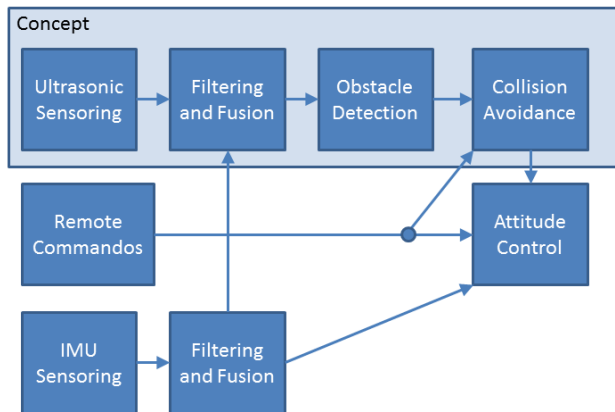

Figure 2: Concept

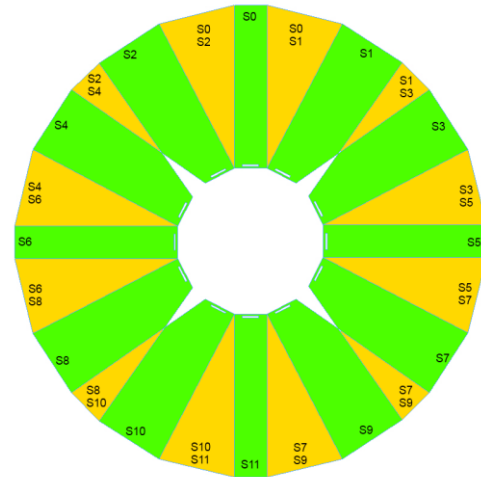

Figure 3: Sectors of Obstacle Detection

1.2 Obstacle Detection

In the obstacle detection module, redundant ultrasonic sensors are used to increase detection resolution and sensor data reliability. Since ultrasonic sensors have a wide dihedral detection angle, the resolution of detected obstacles is very low. The implemented approach uses always two ultrasonic sensors for one half of the same angle. Hence, though the double amount of sensors is needed, the redundancy and resolution is also doubled. Figure 3 shows the implemented constellation using 12 ultrasonic sensors for a 360 degree circle. For example sensor S0 and sensor S1 share one half of their total angle.

1.3 Collision Avoidance

The collision avoidance module divides the area around the quadcopter dependent on the measured distance into three zones for each direction (Figure 5):

- Far or safe zone (green)
- Close zone (yellow)
- Dangerous zone (red)

The behavior of the collision avoidance module can be described best with a state machine (Figure 4). Initially and if the autonomous collision avoidance is off, the quadcopter is in state 0. If the autonomous mode is activated, the quadcopter can switch between state 1, 2 or 3 depending on the measured distance to a nearby object. State 1 (safe zone) is active, if there is no obstacle nearby (object distance $> a+b$). If an obstacle is detected in the close zone ($a > \text{object distance} > a+b$), state 2 (close area) is activated and the corresponding pitch or roll angle towards the obstacle is limited depending on the measured distance reducing the speed of approach. In the dangerous zone ($a < \text{object distance}$), state 3 is activated and the distance to the obstacle is controlled using a PID

controller, preventing a further approach to the obstacle. Hence, such a state machine is necessary for every direction.

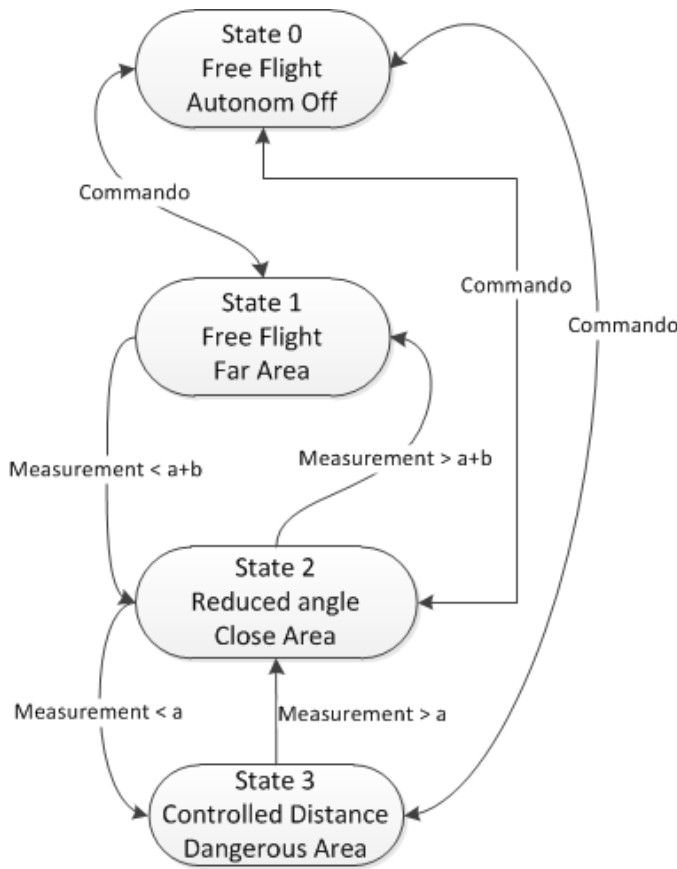

Figure 4: Collision Avoidance

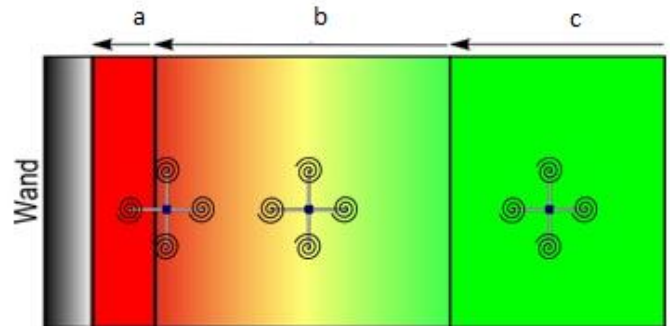

Figure 5: Distance Zones

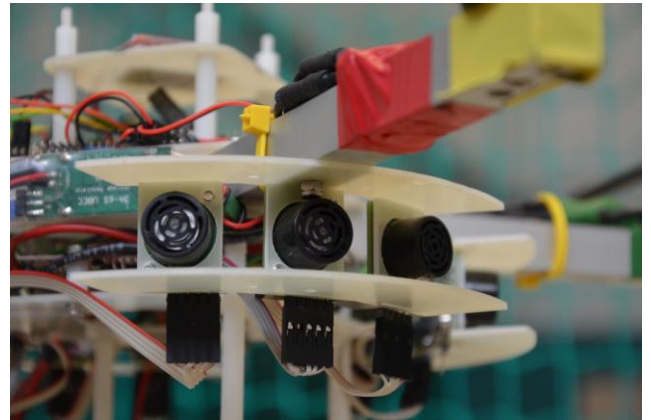

Figure 6: Sensors with Holder

2 IMPLEMENTATION

The presented concept has been implemented and integrated in the self-developed quadcopter (Figure 5) of the chair. The SRF02 ultrasonic sensor has been chosen because of its low price, high range of measurement, and easy communication interface for several entrants using I2C interface.

The sensor has been mounted using GFK plates cutted with a CNC. One sensor holder (Figure 6) with three ultrasonic sensors has been mounted on each side arm of the quadcopter. The three sensors of one side arm are fused to calculate the distance data for the collision avoidance of one direction. Hence the collision avoidance module uses four directions and consists of two collision avoidance state machines (Fig. 4) dedicated to the roll and pitch angles.

The constellation and number of 12 ultrasonic sensors derives from the approach of redundancy as well as the 55° dihedral angle that the SRF02 ultrasonic sensor provides. At least 7 sensors are necessary to cover a 360° circle range. For double redundancy this leads to 14 ultrasonic sensors. However, the experimental results have shown that using 12 sensors in four groups of three sensors on each side gives better results. This simplifies the geometrical design and increases the possible sample time of the system. Furthermore each sensor has a 20° tipping angle from the perpendicular on the object. A higher tipping angle of an object is not detectable anymore, since there are not enough ultrasonic waves reflected from the surface of the object. With 27.5° between every sensor and 20° tipping angle, each three sensor combination of every arm covers 95° tipping angle. Hence all twelve sensors cover every horizontal angle within the minimum tipping angle of 20° and enabling the system to detect a wall at every yaw angle.

One major issue on implementation was the fact that the sensors disturb each other. Though more sensors allow the raising of the sample time and the resolution of objects detection, more sensors also mean more noise and errors. Therefore a trade of between sample time and accuracy had to be made. The best results were found by using 3 activation groups and activate those four sensors with 90° shift angle between each other at the same time. This leads to a group sample time of 30ms and a sensor sample time of 90ms.

Another problem is the fact, that the rotations of the quadrocopter manipulate the ultrasonic measurements. Therefore measurements from the IMU like the angular rate from the gyroscope are used to detect rotations and dismiss incorrect measurements of the ultrasonic sensors.

Figure 7 shows the hardware design of the system. Beside the 12 ultrasonic sensors for obstacle detection two distance sensors, one infrared and one ultrasonic, are used for height control. The system can be steered using a rc controller or a computer via Bluetooth. For steering and debugging a control panel implemented in QT (Figure 8) has been developed for displaying actual obstacle data, controlling parameter and so on. The quadrocopter can also be steered for autonomous positioning using the computer program.

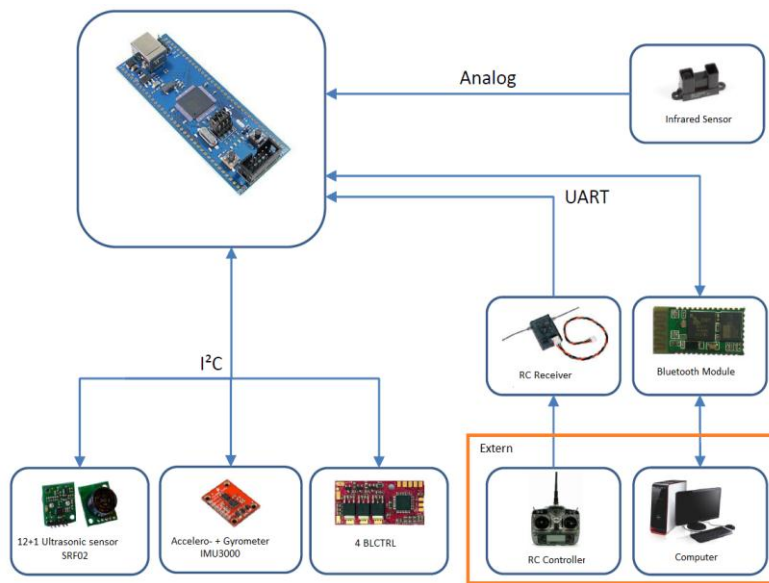

Figure 7: Hardware Design

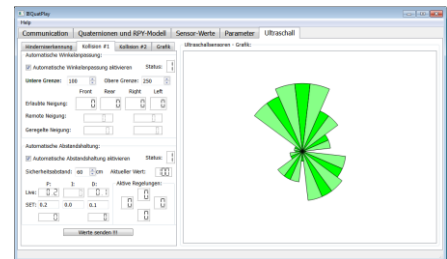

Figure 8: Control Software

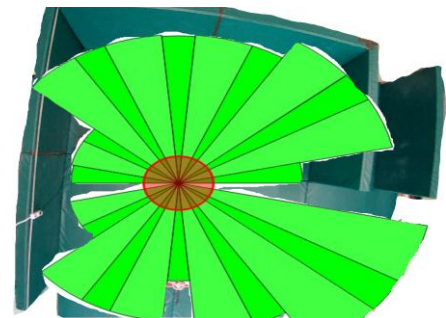

Figure 9: Obstacle Detection

3 EVALUATION

The performance of the obstacle detection as well as the collision avoidance has been extensively evaluated [3].

Under good circumstances, which mean ultrasonic sound reflecting straight surfaces, the system is capable to reproduce its environment with an accuracy of few centimeters. Figure 9 illustrates the results measured in our lab. Furthermore, the evaluation could point out, that the system is capable to detect a wall through smoke, which was not possible with optical sensors. But the system lacks on detecting soft surfaces like foamed material and people wearing clothes. Unlike infrared sensors, ultrasonic sensors are capable of detecting water and glass surfaces.

The collision avoidance module and the implementation of the PID controller to control the distance to an object has been evaluated using the optical tracking system PPT X4 from WorldViz [4]. The stationary distance control has been investigated. Here the system has been steered into a rectangular edge. After reaching the dangerous zone of 1 meter, the collision avoidance takes full control of the quadrocopter and keeps the position in the corner, performing autonomous stationary flight. The evaluation shows, that the system is capable to keep a distance of 1m to an ideal wall with

a standard deviation between 0.05m and 0.15m. At this distance wind reflected from the wall is already a big source of noise for a stable position holding.

Also, the dynamic collision avoidance has been evaluated with two main experiments. In the first experiment, the quadcopter has been flown to a corner with one fixed and one movable wall. After the quadcopter reached its position in the corner, the movable wall has been pushed back and forth, simulating a dynamic obstacle approaching the quadcopter. Thus the quadcopter had to avoid a collision and keep a predefined distance of 1m to the obstacle at the same time. On the way back the quadcopter was following the obstacle autonomously. Figure 10 shows the results of this experiment measured with the optical tracking system. The blue line is the position of the quadcopter and the green line the position of the obstacle simplified on the relevant axis. The maximal lower deviation was 25cm, while the maximal higher deviation was 65cm. These both values of course depend on the dynamic of the movement.

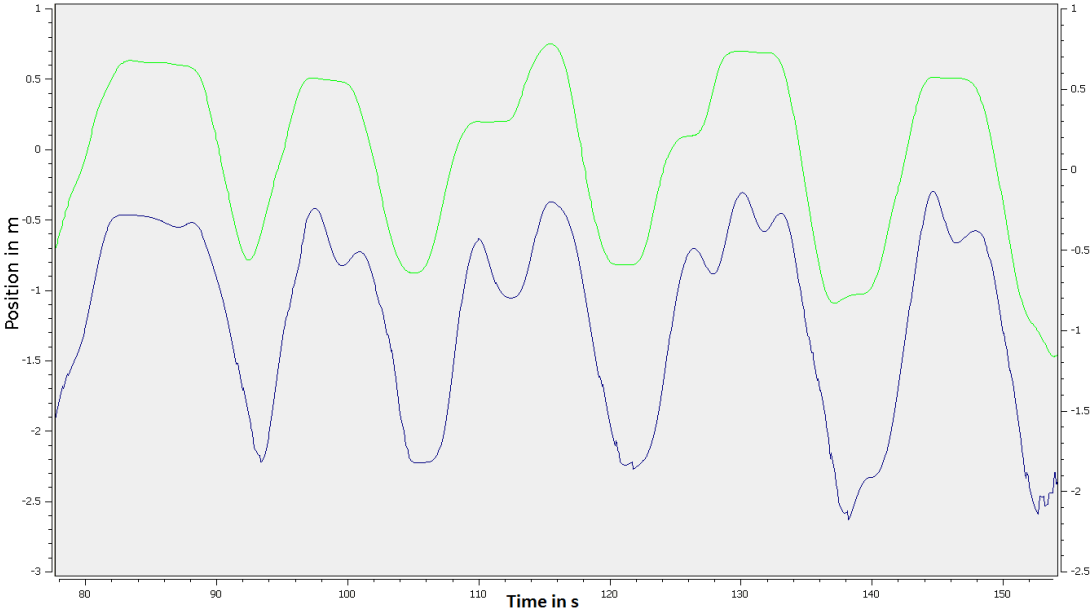

Figure 10: Dynamical Collision Avoidance
Blue: Position of Quadcopter; Green: Position of Obstacle

Figure 11 shows the results of the second dynamic experiment, presented here. Again the quadcopter stood autonomously flying in a corner and the distance to both walls has been changed by remote command from 150cm to 70cm. The quadcopter reaches the new position within 2 seconds.

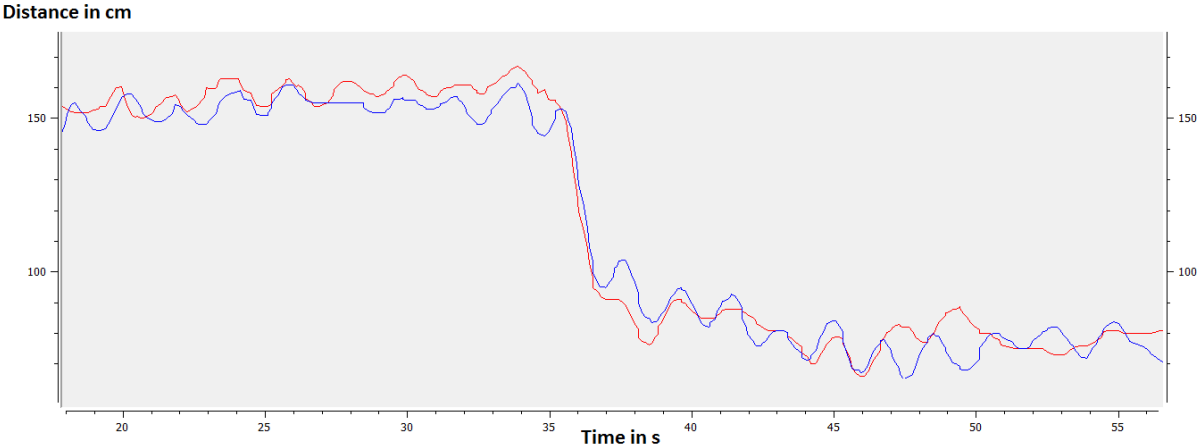

Figure 2: Autonomous Flight

4 CONCLUSION AND PERSPECTIVE

The evaluation shows, that the system is operational and capable to avoid obstacles and enables autonomous functions like collision avoidance and position hold and change. Still, the system lacks of some drawbacks since the ultrasonic sensors only measured distances up to about 250cm reliably, Farer distances and problematic surfaces are not detected at all or with the necessary reliability. Improving the quality of the ultrasonic sensors and fusing these sensors with other systems like infrared is needed to improve the system. Since ultrasonic sensors fail to detect all surfaces, other sensors are mandatory. Nevertheless the experiment has shown that ultrasonic sensors are useful in smoky environments and that autonomous flight using only ultrasonic sensors is possible under certain circumstances.

Though these positive final results, the distribution of the sensors is not optimal, since the angle of the sensors to the surface of the obstacle has to be within 20°. Arranging all sensors in a circle form; this is not always possible depending on the obstacle. Therefore a distribution with the sensors at the end of the arms and with higher angle between each sensor should be more effective, which needs to be investigated.

REFERENCES

- [1] Autonomous Flying Robots, Spring 2010, Kenzo Nonami
- [2] I4Copter: An Adaptable and Modular Quadrotor Platform, SAC 2011, Peter Ulbrich
- [3] Implementierung und Evaluierung eines Systems zur Hinderniserkennung und Kollisionsvermeidung für Indoor-Quadrokopter, Thilo Müller, December 2011
- [4] WorldViz, www.worldviz.com
- [5] Quadrotor Using Minimal Sensing For Autonomous Indoor Flight, 2007, Roberts , EMAV2007
- [6] Coaxial helicopter for autonomous navigation and exploration in gps-denied indoor missions, 2011, Casassa
- [7] Toward obstacle avoidance on quadrotors, de Perrot, DINAME
- [8] Development of an autonomous aerial vehicle using laser range finder, 2010, Raviteja
- [9] Multi-Purpose Environment Awareness Approach for Single Line Laser Scanner in a Small Rotorcraft UA, 2011, Krause, Springer 2011
- [10] Development of Micro UAV Swarms, Bürkle
- [11] Autonomous Landing for a Multirotor UAV Using Vision, 2008, Lange, SIMPAR 2008
- [12] Modelling and Control of a Quad-Rotor Robot, Pounds