

AI supported Multi-Functional Gripping System for Dexterous Manipulation Tasks

Raimund Edlinger¹, Christoph Föls¹, Ulrich Mitterhuber¹ and Andreas Nüchter²

Abstract—Dexterous mobile manipulators that are capable of performing a wide array of tasks are essential for unstructured human-centered environments. Especially in rescue scenarios where time and resources are limited, a gripping system should be as versatile but at the same time as efficient as possible. In addition, situational awareness in accidents and impaired visibility is essential for safely performing missions or automating behaviors, and thus supporting operators. The main contribution of this work is a multi-functional gripping system with technologies and methods for manipulation in rescue and recovery operations as well as for handling hazardous materials. The gripping system is supplemented by an RGB and thermal camera and object detection algorithms, which run in real-time on an embedded device for robust recognition in harsh and dynamic environments. The proposed multi-functional gripping system has been thoroughly evaluated and tested in laboratory experiments and real field facilities.

I. INTRODUCTION

Rescue and recovery operations as well as reconnaissance and transport tasks are often challenging and stressful situations for emergency forces and usually also involve a certain potential for danger. Factors such as confined spaces, dense smoke, toxic fumes, enormous heat and explosion hazards, see Fig. 1, make efficient planning and safe implementation of optimized mission strategies difficult. The support of robotic systems with automated functions offers the potential to reduce these stresses and dangers for humans. The prerequisite for this is that such systems have the necessary capabilities for sensing and analyzing the environment and can also use these for the independent implementation of tasks. While many commercially available grippers are intended and designed for industrial applications, the development of gripping tools for mobile manipulation tasks poses additional challenges. Often, the range of possible tasks to be solved by a single gripping system is much larger, with larger variations in object size, material and surface, unpredictable distance – and therefore gripping angles – between object and robot, and varying light and environmental conditions. The gripping system has to be compact and lightweight in order to allow maximum robot mobility and dexterous manipulation [1].

More generic solutions like anthropomorphic and bio-inspired hands [2] offer great flexibility and may be more quickly installed, but they often require more training for human controllers to make use of their full potential. Also,

¹Raimund Edlinger, Christoph Föls, and Ulrich Mitterhuber are with University of Applied Sciences Upper Austria, 4600 Wels, Austria raimund.edlinger@fh-wels.at

²Andreas Nüchter is with Informatics VII - Robotics and Telematics, Julius-Maximilians University Würzburg andreas.nuechter@uni-wuerzburg.de

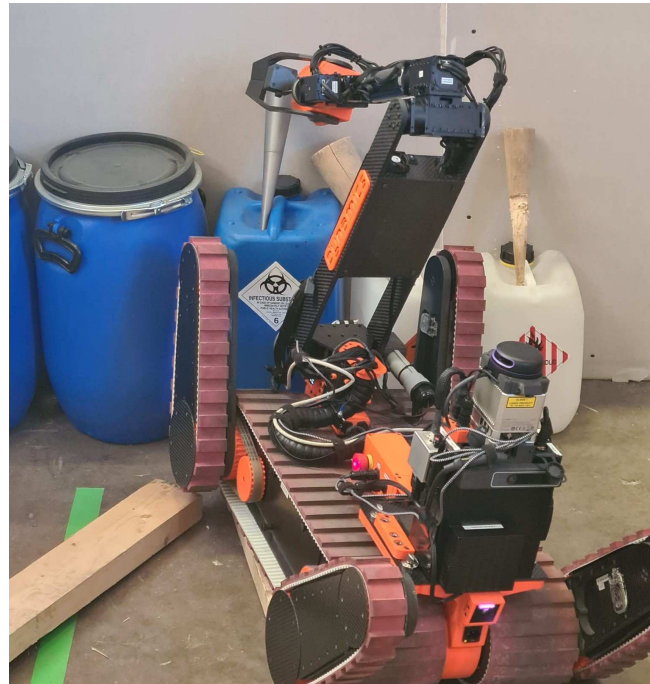

Fig. 1. Dexterous manipulation tasks for securing hazardous substances.

they may not be the fastest tools for a specific task if time is an issue. On the other hand, designing a gripping system for a specific task alone may severely reduce the robot's application potential, as changing tools during an operation is often not an option. Therefore, in mobile applications, a good balance between design specificity and flexibility has to be found, emphasizing the high importance of requirements analysis in the development of gripping systems for such applications.

Manufacturers distinguish robot arms and grippers by their intended applications or the applied gripping concept. Intended applications may be the maneuvering of items of certain sizes and weights, or the manipulation of equipment like door handles, valves or levers. Grippers may also be used for inspection purposes if cameras and lights are installed. The latter could be the specific use, for example when reading meters, or a feature to assist actual gripping or manipulation. Whereas the state of the art of autonomous grasping technology focuses on agricultural [3], [4] and industrial application [5], [6], [7], this work focuses on the support of rescue operations.

In order to enable a robot or gripping system to decide what gripper modality should be used, it must be able to

process input data from sensors. In recent years many novel deep learning based computer vision algorithms for object detection such as proposed in [8] have been published. Another factor, which enables mobile robot platforms to utilise deep learning based algorithms, is the rapid improvement made in computation. Embedded platforms such as the *NVIDIA Jetsons* provide a high performance GPU at low power consumption. When automating tasks in rescue scenarios, different object classes must be recognized by the robot from object recognition algorithms. The first class to note here are hazmat signs which highlight dangerous locations. The works in [9] and [10] proposed deep learning based algorithms for hazmat sign detection. Another class of relevance are manometers which are integral to monitor the state of a system. The authors of [11] investigated object detection of manometers. Further relevant classes for rescue robotics for which object detection algorithms were developed are doors and door handles. It is obvious that an autonomous robot must be able to detect doors and door handles in order to be able to traverse through them. In [12] a system for door handle detection only was proposed while [13] proposes a system for both door and door-handle detection.

RGB camera based computer vision applications work however only in daylight conditions. To solve this problem, infrared imaging sensors can be used to obtain useful vision data when RGB does not work. Works such as [14] show that the aforementioned RGB focused deep learning algorithms can also be used for object detection on infrared images.

The general objective of the proposed paper is to automate recovery processes in which the emergency services are exposed to a wide variety of hazards. The results demonstrate a multi-functional gripper system with an AI based object detection. The rescue robot platform is evaluated in real experiments and selected test scenarios. The main contributions of this work are summarized as follows:

- multi-functional gripper for effective mobile manipulation
- AI based object detection for manipulator selection
- demonstration of our approach by using a mobile rescue robot with a 6-DOF manipulation system (Fig. 2)

II. MULTI-FUNCTIONAL GRIPPER DESIGN

Robotic gripper technology enables robotic arms to interact with objects and the environment. Depending on the type of gripper chosen, each gripper system has its advantages and disadvantages for extreme precision and repeatability in execution and sensitive handling of complex and/or fragile objects. The gripping system must be transported by the robot, communicate with the robot and be adapted to the robot's body size so that it is able to maneuver freely. If rescue tasks are to be incorporated into the robot's repertoire, the gripping system's holding strength and stability have to be aligned with the robot's lifting/carrying/pulling strength as well as the target object's shape and weight. The same is true for opening doors, which requires a complex combination of recognizing and turning a door handle, pushing or pulling

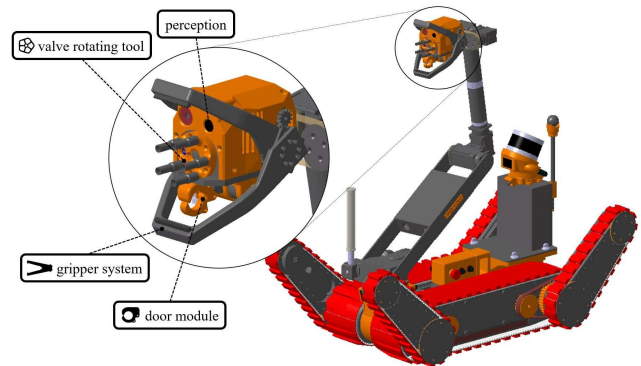

Fig. 2. Rescue robot with 6-DOF manipulator and multi-functional gripper.

and holding the door open, and moving - or at least looking - through the door.

A. Application Oriented Gripping System

The automation of different tasks performed by a mobile robot supports the operator to fulfill this requirement. Additionally, it allows the robot operator to focus on other tasks because it is only necessary to evaluate the automated execution instead of executing the task manually. Dexterous manipulations tasks in search and rescue scenarios are:

- manipulate valves (opening and closing)
- open and close different types of doors
- finding POIs (fire extinguisher, emergency exit, hazmat labels) and inspection tasks (manometer reading)
- grasp objects and precise manipulation

Especially the handling with a door requires an easily manoeuvrable robot system with a multi-axis robot arm. Mobile robot systems cope with pushing doors in less time than doors pulling. On the one hand, a large action radius of the robot arm is already an advantage, but on the other hand, the execution of the task also depends on the mobility of the entire system. Legged robots [15], [16], [17], omniwheels or other types of holonomic robots can move in any position during manipulation, whereas tracked robot systems are much more limited. The Centauro project aimed to increase the applicability of mobile manipulation robots in real-life operations by developing a highly flexible disaster relief system [18].

B. Sensor Integration and Perception

Since accurate manipulation is dependent on high quality sensor information, the gripping system must provide suitable sensors, such as well-placed cameras or pressure sensors. While in industrial environments appropriate lighting can be set up separately from the robot, in mobile applications the robot must have an integrated lighting source that can be adjusted via a PWM signal. A particular challenge is the interference-free mounting of cameras and lighting in addition to the actual gripping mechanisms. Since the gripping system is often the most flexible moveable part and can extend outside the robot's core body, it also plays an important role in exploration tasks. This is specifically true

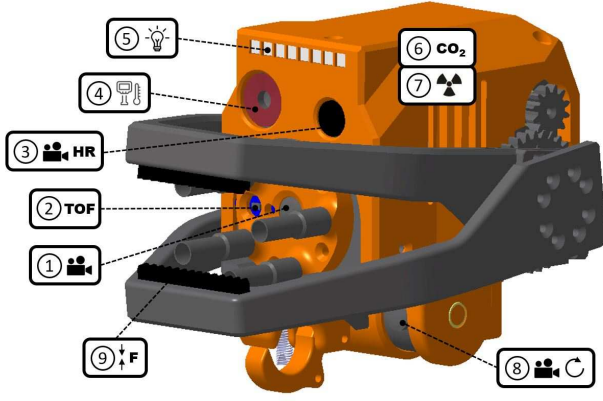

Fig. 3. Sensor integration and perception concept.

where objects have to be inspected from several perspectives and angles or within other objects or holes. In order to find and locate points and objects of interest – like fire extinguishers, emergency exits, or hazmat labels – appropriate sensors, like cameras of sufficient resolution and distance measuring devices, have to be placed and their respective information processed and matched to other available information like 2D or 3D maps. Hence, the following sensors have been selected and integrated into the multi-functional gripper (Fig. 3):

- 1) RGB analog camera
- 2) TOF (time of flight) distance sensor - VL53L0X
- 3) IDS-UV-1551-LE RGB USB camera
- 4) Seek CompactPRO XR IR camera
- 5) Matek LED Stripe
- 6) CO₂-sensor Senseair S8¹
- 7) Nuclear beta and gamma radiation sensor BG51²
- 8) RGB analog camera pivoted
- 9) Self developed tactile pressure sensor [19]

C. Gripper Concept

1) *Grasping general objects with integrated tactile sensor:* Gripper systems with sensitive sensor technology, as well as robot hands, are also becoming increasingly important in mobile robotics. The new gripper concept benefits from symmetrically operating jaws and hence, enables grasping objects with a maximum dimension up to about 11 cm. With the developed tactile sensor system [19] inside the gripper jaws, the object can be gripped securely and the gripping force can be controlled with the feedback from the sensors.

Essentially, the pressure sensor consists of two copper strips separated by a pressure-sensitive Velostat[®] foil³ (see Fig. 4 left/center). Furthermore, a voltage divider circuit as shown in Fig. 4 right, where the foil basically acts as a potentiometer is used. The electrical resistance of the foil, which decreases under pressure, affects a voltage change at the circuit output. The output voltage is measured, digitized

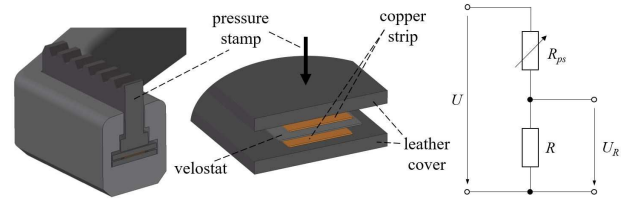

Fig. 4. Pressure sensor of the gripper jaw.

by means of an analog-to-digital converter (ADC) and visualized on the operators screen.

The tactile pressure sensor is supplied with $U = 3.3\text{ V}$. Unstressed, the resistance of the Velostat[®] foil is about $1\text{ k}\Omega$ whereas a self-set realistic upper limit of about 1 kg results in approximately $75\ \Omega$. With the equation

$$\frac{R}{U_R} = \frac{R_{ps} + R}{U} \implies R = R_{ps} \cdot \frac{U_R}{U - U_R} \quad (1)$$

and the desired voltage range of the sensor from $0.3 - 3.0\text{ V}$, the possible value range of the circuit divider resistor is determined with $100 - 750\ \Omega$. Equation (1) gives the following sensor output:

$$U_R = U \cdot \frac{R}{R_{ps} + R} \quad (2)$$

Table I lists the parameters for the tactile sensor, valve and gripper tool:

TABLE I
PRESSURE SENSOR AND GRIPPER PARAMETER.

Parameter	Description
U	supply voltage of the voltage divider circuit [V]
U_R	circuit divider output voltage [V]
R	circuit divider resistor [Ω]
R_{ps}	pressure sensor resistance [Ω]
F_G	gripping force [N]
m	work-piece weight [kg]
g	gravitation [m/s^2] = 9.81
a	acceleration [m/s^2] = 0
S	safety factor [-] = 2
μ	coefficient of friction [-] (plastic against steel) = 0.5
M_6	axis 6 torque [Nm] (Dynamixel PH42-020-S300-R)
r_{valve}	tool pins engagement radius [m]
$r_{gripper}$	gripper length [m]

The gripping force calculation for parallel grippers is based on a friction-locked connection. The torque and the lever length result in the following total gripping force:

$$F_G = \frac{M_6}{r_{gripper}} = \frac{5.1\text{ Nm}}{0.1425\text{ m}} = 35.79\text{ N} \quad (3)$$

The calculation of the handling weight is:

$$F_G = \frac{m \cdot (g + a)}{\mu} \cdot S \quad (4)$$

$$m = \frac{F_G \cdot \mu}{(g + a) \cdot S} = \frac{35.79\text{ N} \cdot 0.5}{9.81\text{ m/s}^2 \cdot 2} = 0.912\text{ kg} \quad (5)$$

¹<https://senseair.com/products/size-counts/s8-residential/>

²<https://www.gvzcomp.it/products-technologies-separator/teviso/beta-and-gamma-ray-sensor/radiation-sensor-bg51>

³<https://www.adafruit.com/product/1361>

2) *Valve turning*: The problem of robot-controlled turning of valves has been investigated in some studies [20], [21] and approaches to the 2015 DARPA Robotics Challenge Finals [22], [23], [24]. By turning the valve, the distance between the object and the gripper tool varies over time. Therefore, one challenge is the continuous tracking and adjusting of the gripper to this change. Our solution including an additional tool screwed to the gripper front allows to capture smaller valves relatively easily and compensates deviations in valve size and longitudinal offset to a certain extent. For execution, it is important that the 6-DOF manipulator can rotate the whole gripper module, i.e. the valve tool, endlessly (axis 6 in Fig. 5) to complete the task in the shortest possible time. Fig. 5 shows the CAD model and the use of the valve tool, which enables operator-friendly manipulation. The figure demonstrates that the tool does not have to be exactly congruent with the rotation axis of the valve and theoretically can tolerate a threading of $\pm 30^\circ$ without any loss of manipulation performance. The rotation unit itself consists of five rigid tool pins elongated by flexible shrink tubes each, which act as a kind of over-wind protection of the robot arm. Obviously, the valve turning torque is limited by the motor torque of axis 6 ($M_6 = 5.1 Nm$). By means of the tool pins engagement radius r_{valve} the maximum possible force applied to one single tool pin (worst case assumption) is calculated by

$$F = \frac{M_6}{r_{valve}} = \frac{5.1 Nm}{0.0225 m} = 227 N \quad (6)$$

and used for dimensioning.

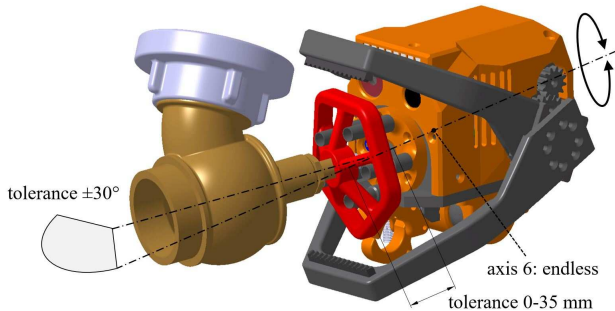

Fig. 5. Valve turning tool in various positions.

3) *Door opening*: In recent years, the identification of different handles and doors has been widely studied [25], [26], [27]. A major difficulty is that you can not distinguish between push and pull doors, whereas pushing doors are easier to automate than pulling doors. The legged robot from Boston Dynamics (SpotMini)⁴ impressively demonstrates how to open security doors. But you can also see in the video⁵ that, in addition to the robot arm, a foot is required to open the door. This technique for door opening is also used

⁴<https://www.bostondynamics.com/products/spot/arm>

⁵<https://www.youtube.com/watch?v=wXxmussq4E>

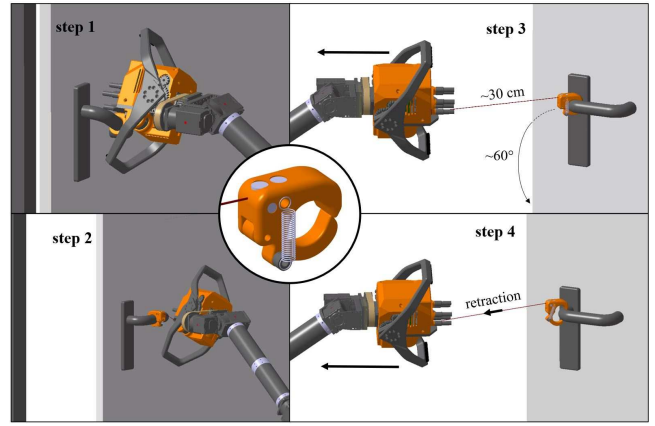

Fig. 6. Principle procedure when opening the door with the newly developed door module.

for mobile tracked robots with a flipper system. However, if the robot arm does not have the necessary working space, it becomes very difficult to open doors. To solve this problem, a tool was developed which hangs on a rope and thus increases the working space of the arm, see Fig. 6.

III. AI BASED MANIPULATION CHOICE

In order to manipulate or inspect objects in the robots environment, it needs to be able to interpret it. This involves first collecting environmental data from sensors, which is then fed into an algorithm that provides an interpretation as output. In this work, the interpretation of the environment is used to subsequently decide which gripping tool is best suited for the particular application. The overall architecture for interpreting the environment and making decision based on it is shown in Fig. 7. First sensor data is fed into an AI algorithm which is a deep neural network for object detection. The following sections describe in more detail the sensors, the object detection algorithm including its training. An RGB camera located in the top right of the gripper and an infrared camera located at the top left of the gripper are used (Fig. 3).

The motivation for the different types of cameras is that rescue robots often operate in dark or smoky environments. The object recognition algorithm is based on the *YOLO* family [8] published by researcher Glenn and his team with the newer version *YOLOv5*⁶. It was chosen for its state-of-the-art performance and it is running in real time on an embedded platform such as the *NVIDIA Jetson Nano*. For each sensor modality a dedicated dataset was created and a model was trained. A dataset was created for the RGB camera with images of hazardous material signs, manometers and their needles, doors and door handles, and valves. However, to increase the dataset's size, publicly available datasets were included as well. More specifically, the hazmat sign dataset provided by [10] and the manometer dataset provided by [11] were used. In total, the RGB dataset contains 5418 images

⁶<https://github.com/ultralytics/yolov5>

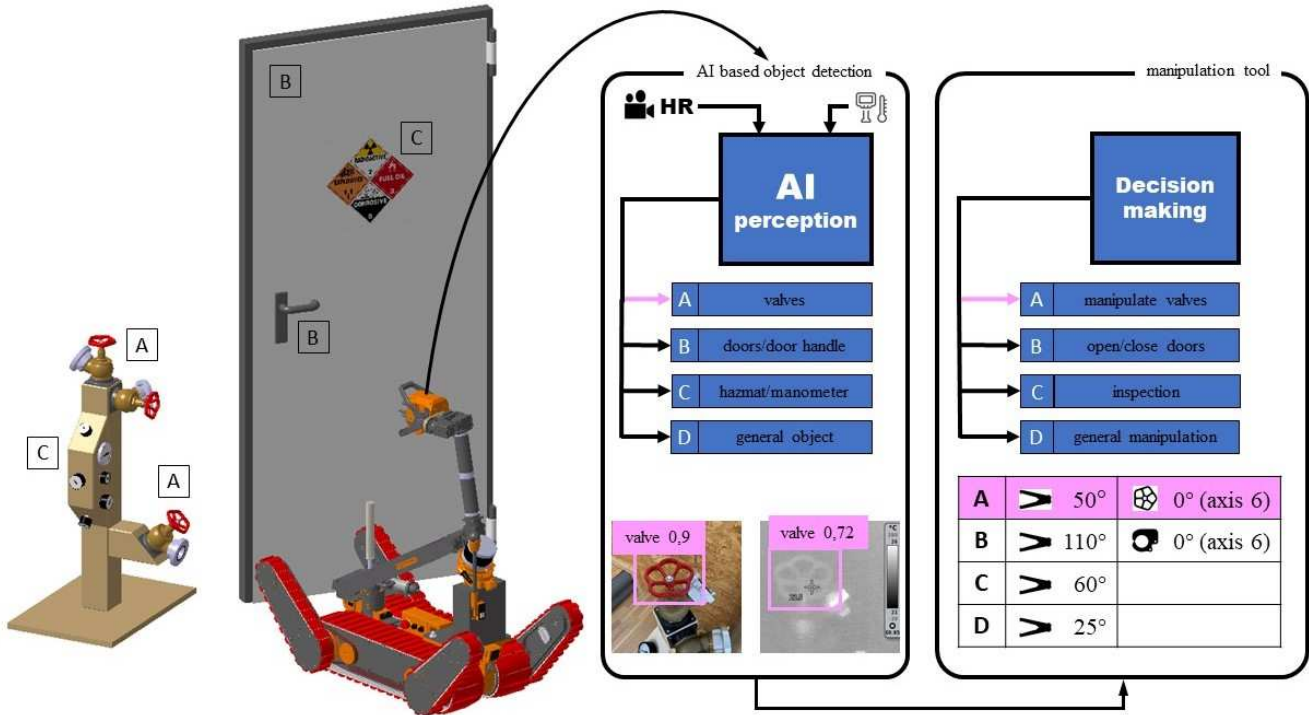

Fig. 7. New gripper concept for dexterous manipulation tasks with a tracked rescue robot: (A) valves, (B) door or door handles, (C) hazmat labels or manometers.

with a size of 640x480. Table II shows the included classes and the respective object count for each class.

The images of the infrared dataset were all taken in the lab. It only contains instances of valves and has in total a size of 349 images with a resolution of 320x240. The detailed training data splits, results and inference examples are given in the experimental results in section IV.

TABLE II
RGB DATASET OBJECT COUNT.

Class ID	Class name	Instance count
0	hazmat_poison	479
1	hazmat_oxygen	815
2	hazmat_flammable	1427
3	hazmat_flammable_solid	682
4	hazmat_corrosive	626
5	hazmat_dangerous	869
6	hazmat_non_flammable_gas	974
7	hazmat_organic_peroxide	816
8	hazmat_explosive	1042
9	hazmat_radioactive	1367
10	hazmat_inhalation_hazard	676
11	hazmat_spontaneously_combustible	125
12	hazmat_infectious_substance	673
13	hazmat_other_hazmat	400
14	manometer	455
15	manometer_needle	323
16	door	593
17	door_handle	698
18	valve	159

Once the AI system has processed the sensor inputs,

the tool decision can be made. Currently, the RGB model supports four different decisions which are (A) manipulate valves, (B) open/close doors, (C) inspection and (D) general manipulation while the infrared model only supports two which are manipulate valves and general manipulation. The tool decision is made based on the current bounding boxes detected in the image. If multiple bounding boxes are located in the image, no tool decision is made. This is based on the assumption that the gripper must still be far away from a specific object. As soon as only a single bounding box is detected in the image, the tool decision is made.

IV. EXPERIMENTS AND RESULTS

For robots in search and rescue applications, sample scenarios have been developed for the DARPA Robotics Challenge (DRC) [28], RoboCup Rescue League [29], [30] and EnRicH competition [31], ranging from exploration and manipulation tasks to search and rescue missions in simulated and real scenarios. Due to regular rule changes and new tasks, the robotics competitions are designed in such a way that the teams have to further develop their robot systems every year. These advances also mean that new concepts are needed to meet the demanding mobility and manipulation tasks in the rescue sector.

For evaluation and testing, the setup as in the CAD overview (Fig. 7) is reproduced in order to verify functionality, determine working range and practice different scenarios. Industrial equipment which rescue robots are typically confronted with in disaster-response missions (valves,

manometers, industrial doors, etc.) is used.

A. AI-Perception

For training of the two object detection model instances a workstation with two NVIDIA RTX 2080 Ti, 128 GB DDR4 RAM, and an AMD Ryzen 9 3950X CPU was used. For the RGB and the infrared model as well, training was done over 200 epochs with a batch size of 90 images split over the two GPUs. To increase the robustness of the models, data augmentation methods such as random image rotation ($\pm 20^\circ$), horizontal flipping and image scaling (0-50%) were applied. The RGB dataset was split into 4334 training, 542 validation and 542 test images. The infrared dataset was split into 251 training, 49 validation and 49 test images. During training the RGB model achieved a mean average precision 0.5 on the RGB test dataset of 97.2% and the infrared model achieved a mean average precision 0.5 of 95.1% on the infrared test dataset. Qualitative results of the models predicting on unseen images in the laboratory are shown in Fig. 8 and Fig. 9 for infrared and RGB respectively. For inference, the model was deployed on an embedded platform within the rescue robot, more specifically the NVIDIA Jetson Nano. The deployment was done within a ROS node implemented in plain Python and PyTorch with no optimisation frameworks such as TensorRT.

Due to the restricted field of view of the used camera and minimum resolution requirements, the object detection algorithm only performs reliably in certain distance ranges to objects. Therefore a study aiming to determining the valid distance ranges for the RGB model only was conducted. It was defined that a prediction is reliable if it's confidence delivered by the object detection algorithm is above 0.5. The classes defined relevant for this study are hazmat, containing all different hazmat labels, manometer, door, door handle and valve.

The measurements were done with an RGB camera of the robot gripper delivering images with a resolution of 640x480 pixel. For each measurement, data points were collected over a range of 0–10 m distance between camera and object. The robot was moved in 0.2 m increments, where

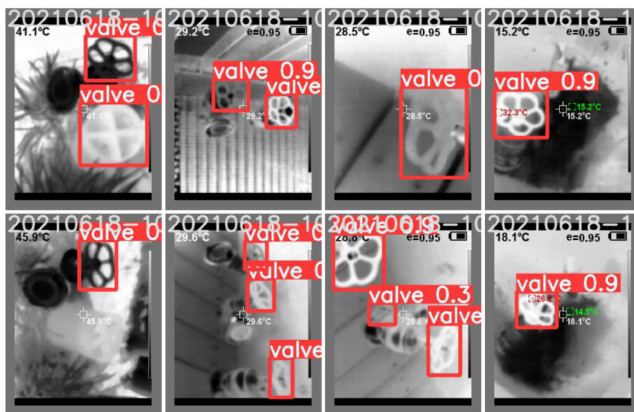

Fig. 8. Infrared valve object detection sample result.

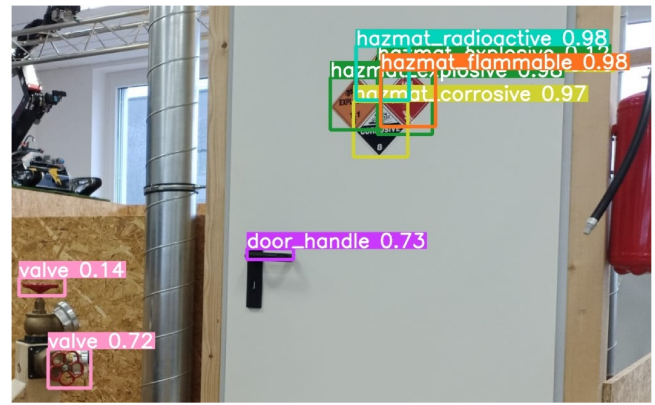

Fig. 9. RGB object detection sample result.

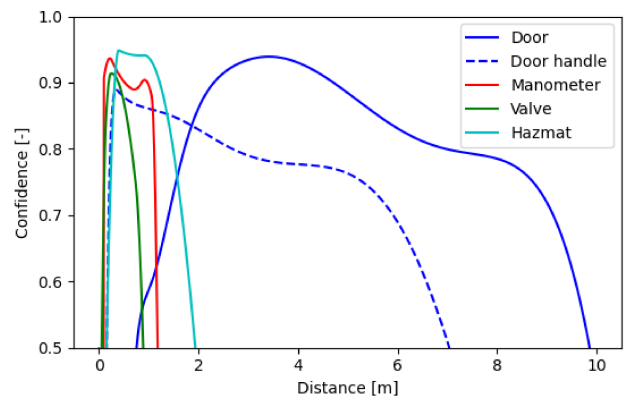

Fig. 10. Object detection reliability over the object distance for multiple object classes of the RGB model.

at every increment the current object detection confidence was logged. One measurement series was recorded for each object. In the future, this will be expanded with further measurement series and thus provide information on how robustly the objects are detected and at what distance. The results of this measurements are shown in the diagram in Fig. 10. A spline interpolation has been used to smooth the measurement curve for better readability. The graph also represents the ranges in which the object detection can be used reliably for each class.

When interpreting the measurement curve, one result is particularly interesting. It was expected that smaller objects such as hazmat labels or manometers would only be reliably detected at shorter distances. This hypothesis could be confirmed for all smaller objects except door handles. The reason for this is that the neural network learned that door handles are usually located in doors. The measurements shown in the graph include only door handles mounted on doors. When testing a door handle that is not mounted on a door, object recognition could only detect it reliably from a distance under 1.9 m. The measurement of the gripper's distance sensor is used to determine if the object detection result should be used. Thus, unreliable object detection results are filtered out.

B. Valve Manipulation

First experiments of the valve tool with variable gripper jaw positions provide practical information about restrictions through the gripping system. Thus, a narrow jaw angle of 41° exhausts the lower limit where valve manipulation is still possible, whereas a wide jaw angle of 64° is significantly more convenient for the operator. The associated restrictions in possible branching angle of pipe attachments to the valve are 45° and 35° respectively.

The second series of experiments deals with the alignment of the valve tool to the valve. Due to the flexibility of the tool, it is possible to position it incongruently and inclined. Detailed test results, including rough assessments about the manipulability, are listed in Table III. Obviously, the possible axis inclination with acceptable tool functionality is much higher than assumed in Fig. 5, which the entire rescue robot benefits from. This is because axis 1 of the robot arm can be used to target valves over a wide range in rough terrain, whereas conventional gripper concepts additionally require a combination of axes 5 and 6 for alignment.

C. Doors

For manipulating doors, the special door handle tool was developed in multiple experiments. Significantly important are both chamfers for grasping the door handle smoothly (Fig. 11 red) respectively fixing it securely and releasing it at the right time (Fig. 11 blue). Empirically determined, the angle of about 60° represents a critical value for industrial door handles. Furthermore, emerged from testing that a circular cross section of the closed module is essential. Hence, even narrower handles are not undercut in grasping position and self-locking during the release process is prevented.

D. General Object Manipulation

For grasping other objects, one makes use of the jaw gripper concept. Symmetrical opening and closing of the jaws facilitates the operation, which is additionally supported by a feedback of the currently applied gripping force, provided by two tactile pressure sensors, one inside each jaw. Investigations regarding characteristics of the sensor yield the results visualized in Fig. 12. The graph confirms the facts published in [32]. Linearity can be observed especially in the higher load range.

TABLE III
EVALUATION OF VALVE MANIPULATION.

Axis inclination [°]	Tool pins engaged	Manipulability assessment [%]
0	5 of 5	100
10	5 of 5	100
20	5 of 5	100
30	4-5 of 5	90
40	3 of 5	80
45	2-3 of 5	65
50	2 of 5	50
55	2 of 5	40
60	1-2 of 5	25

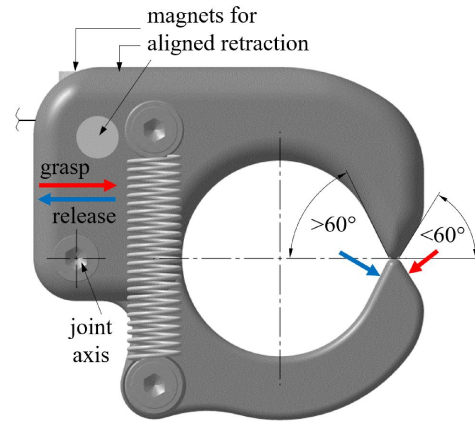

Fig. 11. Door module geometry.

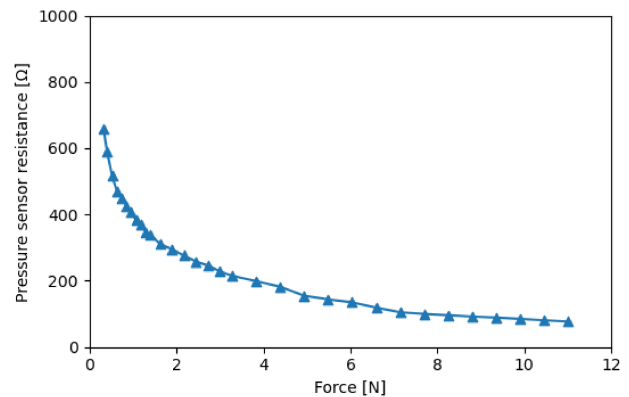

Fig. 12. Sensor characteristics of the tactile pressure sensor.

V. DISCUSSION AND FUTURE WORK

As shown in the experimental results, the AI based object detection for RGB and thermal images is highly capable of recognizing the object classes. In particular, using more heterogeneous environments for data collection would yield major improvements and more classes could be added for inspection. The results can be used to make the right decisions for the tools on the gripper. In addition, we will also investigate in the future what influence the amount of light has on the different camera types.

The numerous field tests with the multi-functional gripping system show that the developed end-effector has great potential. In this respect, for tasks that are still very simple for humans, such as closing valves, the results showed that even if the valve tool is not positioned precisely, the valve can be manipulated quickly.

The new approach for simple door manipulation has also shown that using a rescue robot, especially for pulling doors, promises great advantages. The first prototype was created for laboratory doors with a door handle diameter of 23 mm. An additional work will focus on how to handle the numerous different door handles and geometries with one module. The geometry and tactile sensor technology of the jaw grippers will also be adapted in further tests with other

